

SINGLE PHASE 1 POLE PLUG-IN VOLTAGE TRANSFORMERS INDOOR - E..G.. A/B/C/W SERIES

Dénomination example :

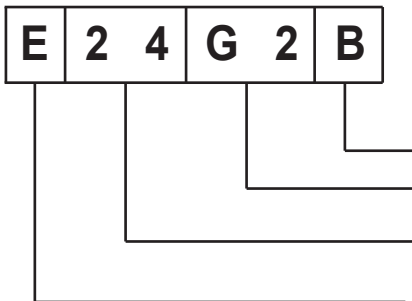

Mould type denomination

- U phase to phase connection
- E phase to earth connection



E24G2B

- **Indoor**
- **7.2 - 12 - 17.5 - 24 - 36 kV**
- **Primary voltage up to 36000/√3 V**
- **Touchproof finish**
- **For metering, protection or auxiliary power**

1-pole voltage transformers vacuum moulded in self extinguishing epoxy resin for the measure of AC voltages between phase and earth up to 36 000/√3 V.

The user connects an insulated cable equipped with a standard female or male plug. Plug-in and plug-out have to be done with no voltage present.

The transformer's surface is coated with a metallic compound that ensures a safe repartition of the magnetic field and zero-potential surface.

The anti-explosion system exclusively deals with secondary fault (short-circuit, maintained overload...).

Under no circumstances it can handle a primary fault (overvoltage, ferroresonance, lightning, switching...)

This system must be associated with a cut-off relay. Maintaining feeding of VT would result in its destruction.

Technical data

Primary voltage U_{pn}	Up to 36 000/√3 V
Secondary voltage U_{sn}	100/√3 - 110/√3 - 100/3 - 110/3 V
Rated output	Up to 25 VA CL 0.2 - 50 VA CL 0.5 100 VA CL 1 - 200 VA CL 3
Accuracy class	0.1 - 0.2 - 0.5 - 1 - 3 - 3P - 6P
Surface finish	Metallic surface
Ambient temperature	- 5°C to + 40°C / 25°F to 100°F IEC - IEEE - CSA - AS - BS - UNE

Other characteristics on request

Secondary voltage U_{sn}	24/√3 to 380/√3 V
Voltage factor	1.5 U_n 30s - 1,2 U_n
Ambient temperature	- 25°C to + 70°C / -13°F to +160°F
Simultaneous loads	Measure and/or protection

Accessoires / Options

Fixing plate	Standard - Several options available
Surface finish	Silicone coating
Anti-explosion device	Option

SINGLE PHASE 1 POLE PLUG-IN VOLTAGE TRANSFORMERS - INDOOR - E..G.. A/B/C/W SERIES

ONE INSULATED POLE - PHASE TO GROUND INDOOR TYPE											
E..G1..	E..G2..	E..G4..	E..G5..	E..G7..	E..G8..						
Drawing type											
Mod.01	Mod.01	Mod.02	Mod.02	Mod.01/02	Mod.02						
General Dimensions. [mm].											
A:	280	A:	340	A:	332	A:	382	A:	500	A:	560
B:	255	B:	307	B:	317	B:	350	B:	458	B:	561
C:	148	C:	186	C:	225	C:	270	C:	335	C:	410
D:	120	D:	120	D:	120	D:	146	D:	200	D:	270
M:	25 kg.	M:	45 kg.	M:	55 kg.	M:	75 kg.	M:	135 kg.	M:	320 kg.

UNE-EN IEC 50181 H.V. PRIMARY TERMINAL TYPE					
TYPE A - up to 24 kV.			TYPE B - up to 36 kV.		
	<p>INTERFACE A 250A DESLIZANTE</p>			<p>INTERFACE B 400A DESLIZANTE</p>	
TYPE C - up to 36 kV.			<p>INTERFACE C 630A ATORNILLADO</p>		

IEEE Std. 386™ H.V. PRIMARY TERMINAL TYPE	
TYPE W - up to 21.1kV.	
	<p>INTERFACE BUSHING WELL 200A</p>

SECONDARY OUTPUT TERMINALS	
Taps:	M6 Screws
Cable:	2 / 3 / 4 / ... copper wire cable

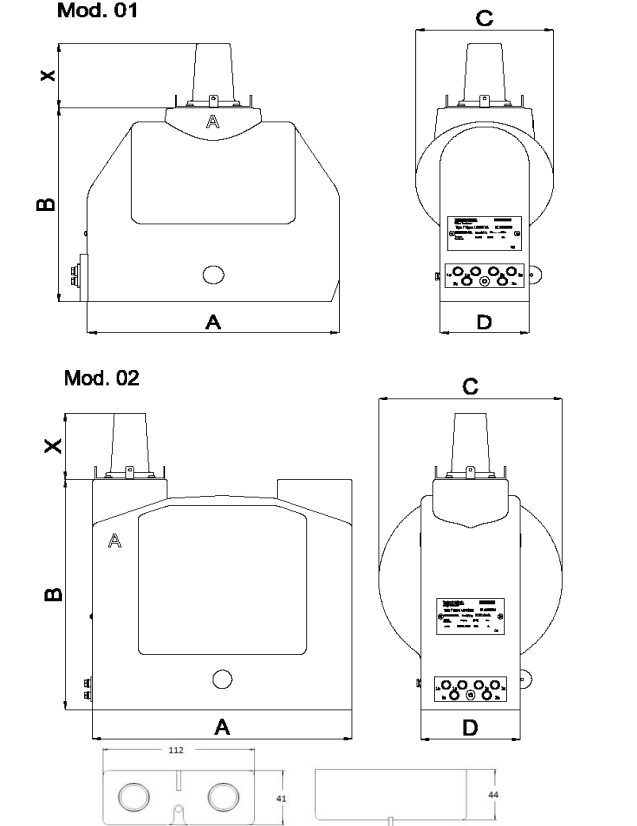

SECONDARY SEALABLE BOX	
Transparent - IP31 - holes: 4 x PG16	

UNE - EN IEC 61869 BURDEN AND CLASS

E..G1..				E..G2..				E..G4..				E..G5..				E..G7..				E..G8..			
Class				Class				Class				Class				Class				Class			
0.2	0.5	1	3	0.2	0.5	1	3	0.2	0.5	1	3	0.2	0.5	1	3	0.2	0.5	1	3	0.2	0.5	1	3
Up to ≤24 kV.				Up to ≤24 kV.				Up to ≤24 kV.				Up to ≤24 kV.				Up to ≤24 kV.				Up to ≤24 kV.			
Burden (VA.)				Burden (VA.)				Burden (VA.)				Burden (VA.)				Burden (VA.)				Burden (VA.)			
15	40	80	180	25	50	100	300	50	120	240	700	80	170	350	1100	400	900	1800	5500	500	1100	2200	6500
Pth.(VA): 250				Pth.(VA): 750				Pth.(VA): 1500				Pth.(VA): 1800				Pth.(VA): 8000				Pth.(VA): 10000			
Up to ≤36 kV.				Up to ≤36 kV.				Up to ≤36 kV.				Up to ≤36 kV.				Up to ≤36 kV.				Up to ≤36 kV.			
Burden (VA.)				Burden (VA.)				Burden (VA.)				Burden (VA.)				Burden (VA.)				Burden (VA.)			
-	-	-	-	20	45	90	250	45	90	200	600	55	130	260	750	350	850	1600	5000	500	1100	2200	6500
Pth.(VA): -				Pth.(VA): 400				Pth.(VA): 900				Pth.(VA): 1100				Pth.(VA): 7500				Pth.(VA): 10000			

IEEE C57.13-2016 BURDEN AND CLASS

TYPE	E15G2..	E15G5..	E25G2..	E25G5..	E35G2..	E35G5..
Description	BIL 95kV		BIL 125kV		BIL 150kV	
Highest Voltage for the material	7.0-7.6 kV.		13.2-14.4 kV		19.1-20.7 kV	
Output Voltage	~					
Lightning impulse withstand voltage	95 kV.		125 kV.		150 kV.	
DELTA / WYE	WYE		WYE		WYE	
Ratio	60:1		115:1		166:1	
Frequency	60 Hz.		60 Hz.		60 Hz.	
Weight						
Thermal Burden						
Class / Burden	0.6 W X M 1.2 W X M Y Z	0.3 W X M 0.6 W X M Y 1.2 W X M Y Z ZZ	0.6 W X M 1.2 W X M Y Z	0.3 W X M 0.6 W X M Y 1.2 W X M Y Z ZZ	1.2 W X M	0.3 W X M 0.6 W X M Y 1.2 W X M Y Z

BASE PLATES - FIXING BRACKETS

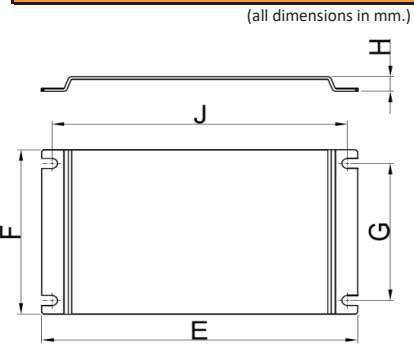

• Other base plates and fixing brackets upon request.

E..G1..				E..G2..				E..G4..				E..G5..				E..G7..				E..G8..			
E	F	G	J	E	F	G	J	E	F	G	J	E	F	G	J	E	F	G	J	E	F	G	J
310	180	150	290	433	186	165	300	310	180	150	290	370	230	200	350	600	340	300	500	700	420	370	670
H.: 16				H.: 5				H.: 16				H.: 17				H.: 20				H.: 20			
Fixation: 4 x Ø 11				Fixation: 4 x Ø 11				Fixation: 4 x Ø 11				Fixation: 4 x Ø 11				Fixation: 4 x Ø 12,5				Fixation: 4 x Ø 12,5			

Please, consult manufacturing options according to requested specifications